



# HOW TO: CUT OUT UNWANTED NOISE

USING PLASTERBOARD SOLUTIONS



GTEC dB BOARD



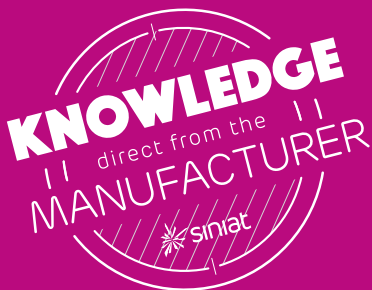

# NOISE POLLUTION

Everyday life is getting louder and noise pollution in and around our homes and places of work is getting harder to ignore.

With living space at a premium more of us are living closer together both in houses and multi-residential properties. Controlling the passage of sound between and within dwellings is becoming increasingly important for everyone wanting to maintain their own personal space.

According to a 2014 'Which?' study, more than a quarter of adults in the UK have had problems with noisy neighbours.



**LIVING SPACE IS TIGHTER THAN EVER**



**NOISE POLLUTION IS INCREASING**

# LEVELS OF NOISE

The level of noise created is measured in decibels (dB), the table below demonstrates how dB ratings relate to real life scenarios of noise pollution.

The example installations provided in this document are designed to provide the best level of protection using products available in the majority of builders merchants and distributors. Further solutions are available on the Siniat website or through our technical services support line.

Any acoustic solution is only effective if it uses the correct components and installation techniques. Removing or changing components and poor quality installation may reduce the level of sound resistance achieved.

## TABLE OF dB RATINGS

R <sub>w</sub> dB	Relative Acoustic Privacy
30	Normal conversation can be distinguished
35	Loud conversation can be distinguished
40	Loud conversation can be heard but not distinguished
45	Loud conversation cannot be heard
50	Shouting can be heard but not distinguished
55	All speech is totally blocked with a high level of privacy from other domestic noise
60	High level of privacy including noise from television or stereos

Normally, in the course of day-to-day life people cannot avoid engaging in activities producing noise. Such noise can lead to disturbance of their neighbours.

Generally, noise can be defined as any unwanted sound. Noise could occur unexpectedly, or be too loud or repetitive. At certain decibels, it can be hazardous to health, with low frequency noise as damaging as loud noise. Noise accounts for most of the complaints that local councils and the Environment Agency receive about environmental pollution, and is a major source of stress.

## TYPICAL CITY NOISE POLLUTION

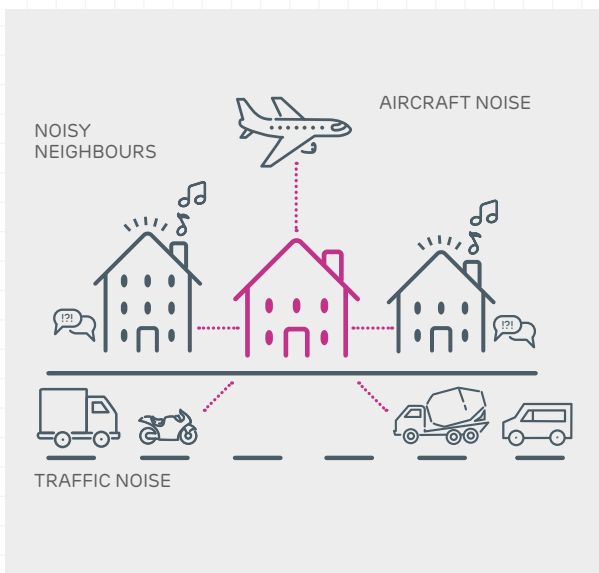

# ACOUSTIC BUILDING REGULATIONS OVERVIEW – APPROVED DOCUMENT E

Approved Document E outlines the acoustic performance requirements for newly built and re-purposed dwellings and offers typical examples of wall and floor build-ups to meet these requirements.

Approved Document E makes an important distinction for performance, separating elements and internal elements:

- Separating element – A dividing wall/floor between two different properties (such as flats).
- Internal element – A dividing wall/floor inside the same property (such as a bedroom wall in a house).

## AIRBORNE

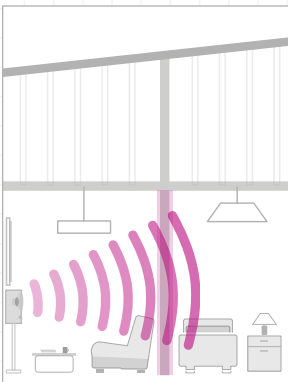

## IMPACT

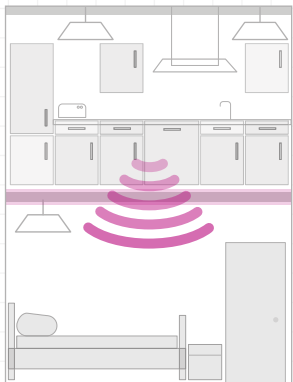

**Note:** Separating elements have much higher performance requirements.

## PERFORMANCE REQUIREMENTS - SEPARATING ELEMENTS

The below diagrams show the performance requirements of separating elements:

- Left is a typical example of a pair of new build semi detached houses, the separating wall requirement for airborne sound transfer is  $45 D_{nt,w} + C_{tr}$  dB.
- Right is a typical example of a new build apartment block, again, requirement for airborne sound transfer is  $45 D_{nt,w} + C_{tr}$  dB but it also has impact sound requirement of  $62 L_{nT,w}$  dB.

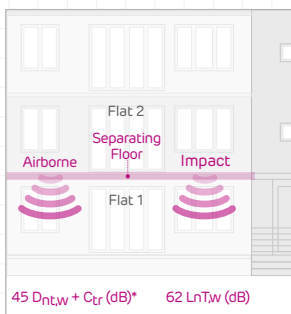
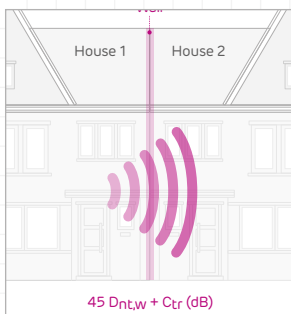

\*Performance requirements shown are for new buildings, there is slight relaxation of requirements for refurbished buildings and rooms for residential purposes (hotel rooms/student accommodation etc.) contact Siniat Technical Services for more detail.

## PERFORMANCE REQUIREMENTS - INTERNAL ELEMENTS

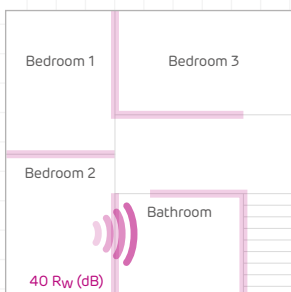

# HOW TO UPGRADE AN EXISTING WALL

A typical example of upgrading the acoustic performance of an existing masonry or block wall would be to use a GTEC Dryliner Channel system, creating a 50mm cavity filled with 25mm glass mineral wool and 2 layers of 12.5mm dB board.

This cost effective solution on any external or dividing wall between dwellings will cut out noise from audio systems, traffic and loud conversation.

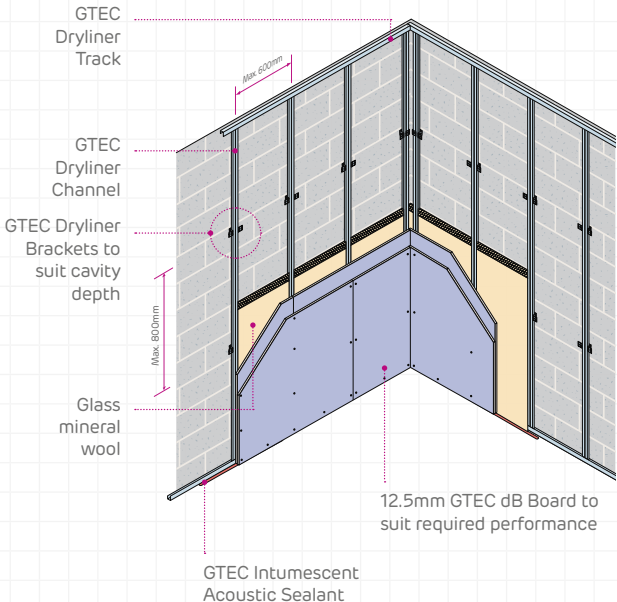



## INSTALLATION

1. Fix a Dryliner Track at 600mm centres to the floor and ceiling using suitable fixings. Allow for required cavity of at least 50mm.
2. Mark vertical lines at 600mm horizontal centres to fix the Dryliner Channels.
3. Start at the centre of the wall and position the Dryliner Brackets directly to the wall at a maximum 800mm vertical centres on the marked lines (at shoulder and waist height). Secure using suitable fixings. Fold out the toothed wings of each bracket to form legs.
4. Cut each Dryliner Channel 5mm shorter in height from the floor to the ceiling and place into the Dryliner Track.
5. Ensure channel is plumb and secure to each bracket using a Pan Head Self Tapping screw.
6. If installing kitchen units, install a Fixing Channel or timber reinforcement at the height the wall and floor units need to be secured.
7. Install the glass mineral wool between the Dryliner Channels ensuring there are no gaps.
8. Cut plasterboard 5mm shorter than the floor to ceiling height. Butt the board firmly against ceiling and fix with Drywall Self Tapping screws at 300mm centres.
9. Install the second layer of boards ensuring that the joints are staggered between the layers.
10. Seal around the perimeter of the boards using Intumescent Acoustic Sealant.

# HOW TO CONTROL INTERNAL NOISE

Offices and commercial areas are noisy environments and ensuring meetings and conversations can take place privately and without background noise can be a challenge.

Within residential environments the challenge can be even greater, with TV's, home cinema equipment and even just general day-to-day activities, rooms within homes and between dwellings in multi-residential properties require better acoustic capabilities.

The following installation shows how an internal/dividing partition can be created to drastically improve the level of acoustic insulation within just an 80 or 100mm deep wall.

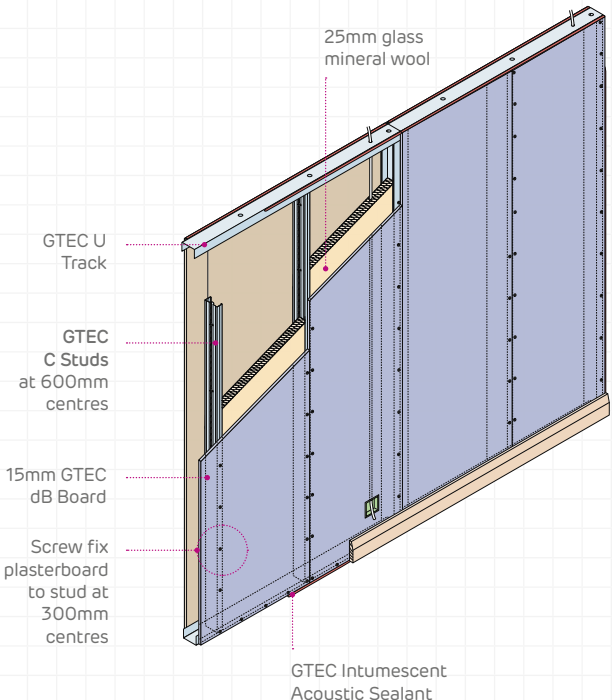

## INSTALLATION

1. Fix U Track to ceiling and floor at the desired location starting at the adjoining wall. Use the C Studs to assist in aligning ceiling and floor studs if required.
2. Cut each C Stud 5mm shorter in height from the floor to the ceiling and place into the U Track, screw to the wall at 300mm centres using suitable fixings.
3. Cut each of the remaining studs individually leaving each one 5mm short, place in U Track but do not fix into position so they can be moved during board installation.
4. Starting with half a board cut the board 5mm shorter than the floor to ceiling height. Butt the board firmly against ceiling and wall and fix with Drywall Self Tapping screw at 300mm centres. Move the unsecured stud to the end of the board allowing room for the next board to be attached.
5. Install the 25mm glass mineral wool between the boards as you install each side ensuring no gaps.
6. Moving to the other side of the partition install a full board marking the centre line and moving the next stud into location at the end of the board. Fix screws at 300mm centres on all 3 studs.
7. Continue with full boards cutting 5mm shorter in length marking the centre of board to highlight the location of each centre stud, installing on alternate sides of the partition for each board. This will set the stud locations perfectly and negate the need for measuring each one individually.
8. To increase effectiveness install a second layer of dB Board each side staggering the joints between layers.
9. Seal around the perimeter of the boards using Intumescent Acoustic Sealant.

# HOW TO CONTROL NOISE FROM ABOVE

Modern flats need to reach strict sound transfer levels, however in older properties the sound barrier can be as little as the floorboards in the room above and the plasterboard on your ceiling.

This simple retrofit solution can be easily installed to provide a significant improvement in the level of noise coming from the room above.

This solution is appropriate to make improvements within one property, contact our technical services team if you are working on floors that will separate two properties.

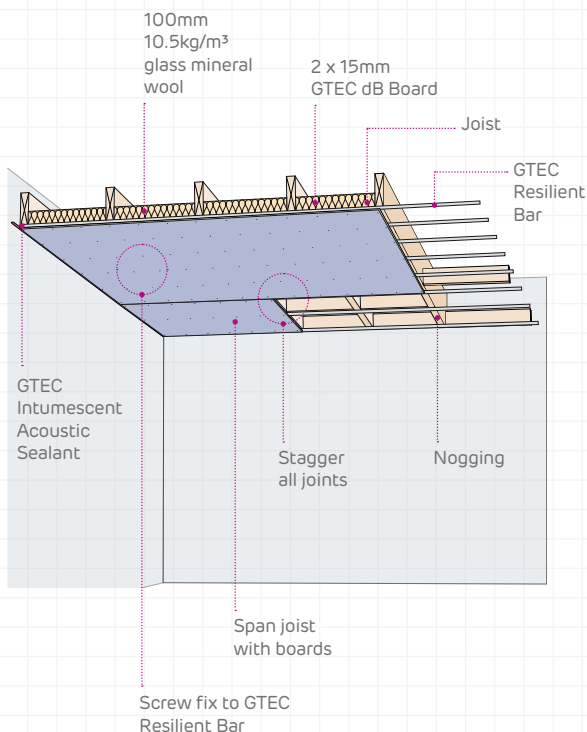

## INSTALLATION

1. Remove existing plasterboard if present.
2. Install 100mm thick 10.5kg/m<sup>3</sup> glass mineral wool between the existing joists ensuring no gaps.
3. Screw Resilient Bar at 150mm centres at right angles to the wooden joists (joists max. 450mm apart) using high thread screws with at least 25mm into the timber.
4. Screw the 15mm dB Board to the Resilient Bar at 150mm centres around the perimeter of the boards and at 230mm centres in the middle of the board using GTEC Self Taping screws.
5. Stagger the joints to help prevent them cracking.
6. Ensure that the board screws are into the Resilient Bar only and that you do not hit any of the joists, if done incorrectly the system will not perform as required.
7. To increase effectiveness further add an additional layer of 15mm dB Board using the same method as above staggering all joints. You need to ensure the board is fixed onto the Resilient Bar, not the joists or just the board.

# HOW TO FINISH THE BOARDS

Taping and Jointing is a simple finishing solution for drylining installations, to reinforce joints to prevent cracking and ensure fire and sound performances are achieved. It is suitable for areas of plasterboard where speed and ease of application can greatly reduce installation time and costs versus a skim finish.

## RECOMMENDED 3 STAGE PROCESS

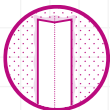

### BEDDING AND FILL COAT

Tape or bead is bedded into the compound and taper filled out.



### 1<sup>ST</sup> FINISH COAT

The taper is re-filled with compound where required.



### 2<sup>ND</sup> FINISH COAT

Final compound layer is applied and sanded for a smooth finish.

## 2 STAGE PROCESS

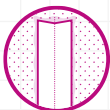

### BEDDING AND FILL COAT

Tape or bead is bedded into the compound and taper filled out.



### 2<sup>ND</sup> FINISH COAT

Final compound layer is applied and sanded for a smooth finish.

## TAPERED EDGE

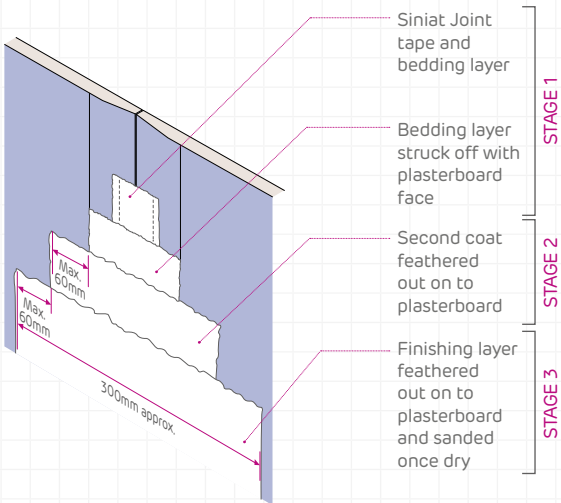
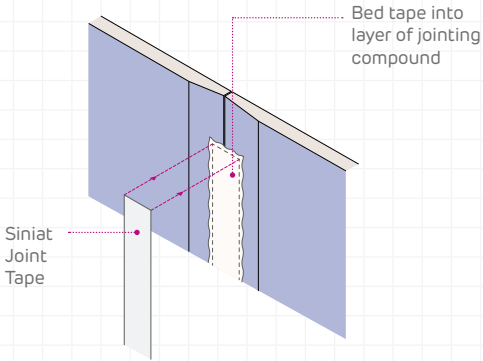

- Tapered edge board provides the best finish by allowing the Joint Tape to sit below the finished surface.
- Board surfaces to be dry, clean, protected from weather, secure and evenly fixed.
- Square edge plasterboard may also be jointed using the method on the following page.

## SQUARE OR CUT EDGE

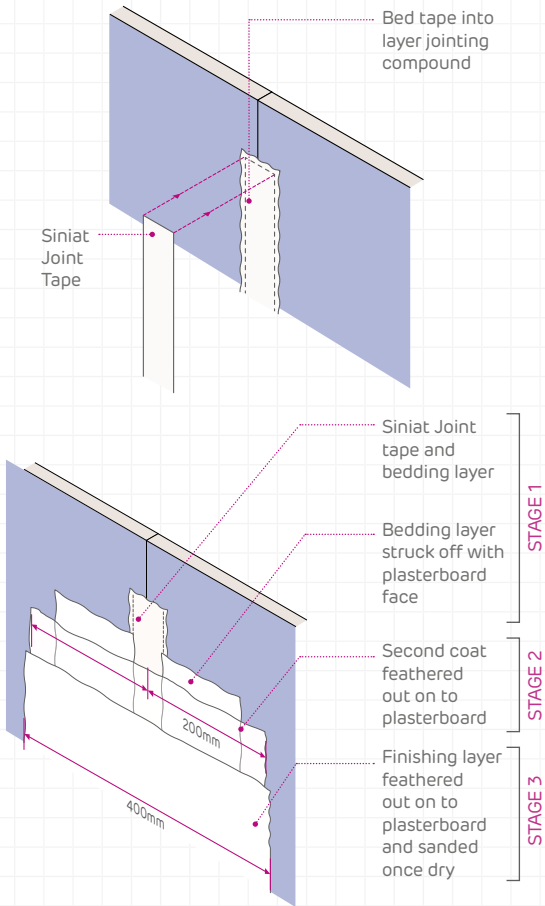

- Correct screw fixings to be used with screw heads just below surface of board.
- Gaps over 3mm to be filled with Siniat Joint Filler or Siniat MultiPurpose Joint Compound prior to tape installation.



## INTERNAL CORNER

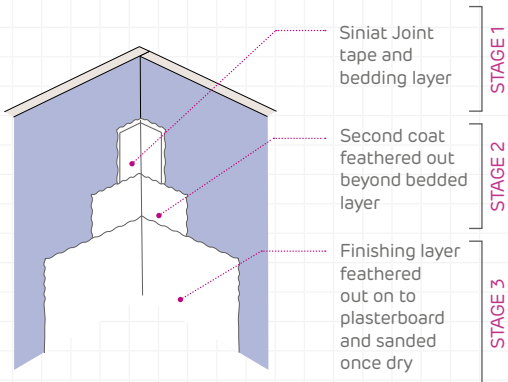
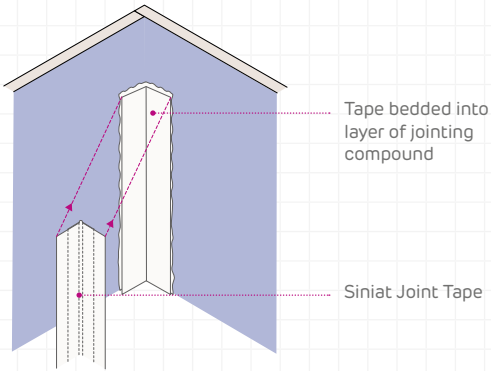

- Compound to be applied in nominal 1mm layers. Thicker layers will extend drying time.
- Siniat Joint Tape cut to length to be pressed into bedding compound.
- Second coat of jointing compound if required to be applied over dry joint, feathered out 50 – 60mm beyond the edge of first coat.
- Finishing coat of compound feathered out 50 – 60mm beyond second coat.
- Finished, dry joint to be sanded to smooth finish for sealing and decoration.

## EXTERNAL CORNER

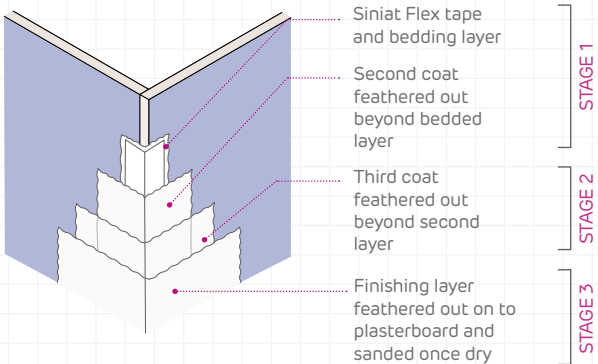
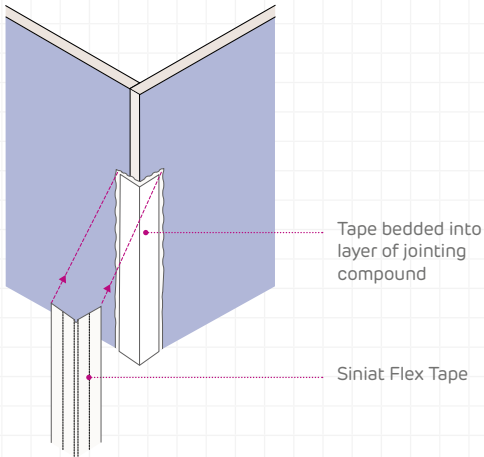

### Square edge joints only:

Joint width to be wider to reduce visible crowning.

### External corners only:

Siniat Flex Tape to be applied in place of Siniat Joint Tape as reinforcement.

## DRYWALL AND UNIVERSAL SEALER



Once the taping and jointing process has been completed, Universal Sealer must be applied to prevent 'regency striping'. When using Siniat Aqua Board, Drywall Sealer must be applied prior to painting/tiling in severe moisture areas.

## REGENCY STRIPING



This term is used to describe the effect of the paint finish reacting differently on the joints to the surface of the board (suction), if the sealer is not applied the joints may be visible no matter how well the taping and jointing process has been completed. Once dry, a paint finish can be applied in the normal manner.



## INSTALLATION TIPS

For a step-by-step video guide and installation tips on sound solutions, how to build a metal stud wall, dry lining and MF ceiling, check out our Siniat UK YouTube Channel.

[youtube.com/siniatukchannel](https://youtube.com/siniatukchannel)

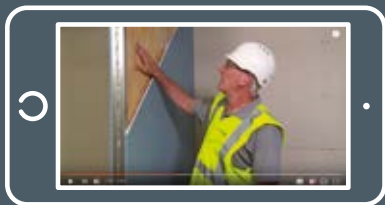

For advice with installation:  
Contact **Technical Services** at:  
[technical.siniat@etexbp.co.uk](mailto:technical.siniat@etexbp.co.uk)  
or call: **0800 145 6033**

[siniat.co.uk](http://siniat.co.uk)

**Etex Building  
Performance Limited**  
Marsh Lane,  
Easton-in-Gordano,  
Bristol, BS20 0NE  
+44 (0) 1275 377 773

